

## Optical Transmission for wireless Microphone and Earphone Transmission Extension up to 1 km

THE ART OF ENGINEERING

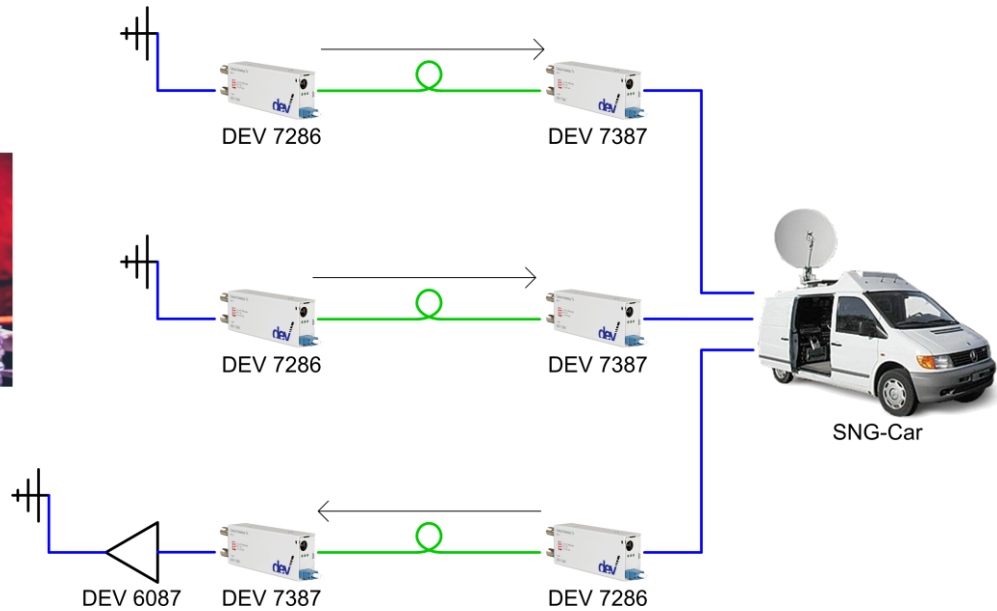

### Products

- DEV 7286** Desktop CWDM Optribution Transmitter; 450...960 MHz; LC/APC
- DEV 7387** Desktop TV Optribution Receiver; 47...1006 MHz; LC/APC
- DEV 6087** Desktop Amplifier; 450...960 MHz

### Features

- ▀ Standalone Optical Transmitter (Tx) Module, Optical Receiver (Rx) Module, and Amplifier Module
- ▀ RF Monitoring Port
- ▀ High Input Power Level Option (DEV 7286)
- ▀ 75 Ohm, precision F (f), and 50 Ohm, BNC (f) Ports available
- ▀ Overtemperature Protection
- ▀ Different Mounting Products are available



The final product may vary from the above image depending on the options selected.

### Link Specifications DEV 7286 & DEV 7387

	Value	Condition
Frequency Range	450...960 MHz	
Link Gain	11±3 dB -33±3 dB	Standard, @ +25 °C (77 °F) Option HIL, @ +25 °C (77 °F)
Flatness	±0.7 dB ±0.2 dB	450...960 MHz In any 8 MHz window
Return Loss	>16 dB, typ. 20 dB	
Nominal RF Input Level	-20 dBm +17 dBm	Standard, aggregated power Option HIL, aggregated power
Noise Figure	<25 dB <70 dB	Standard Option HIL
Noise Floor	<-140 dBm/Hz	
SFDR2/3	110 dB/Hz <sup>2/3</sup> 80 dB/Hz <sup>2/3</sup>	Standard Option HIL
CNR	58 dB 52 dB	Standard, Notes 1, 2, 3 Option HIL, Notes 1, 2, 3
Output IP3	16 dBm	
OP1dB	+3 dBm ±1 dB	
Intermodulation Distortion	>52 dBc >68 dBc	Standard, @ 2 tones, -20 dBm each Standard, @ 2 tones, +14 dBm each
Input Power dynamic Range	-90...-20 dBm -50...+17 dBm	Standard, aggregated power, Note 4 Option HIL, aggregated power, Note 4
Damage RF Input Level	+15 dBm +27 dBm	Standard, aggregated power Option HIL, aggregated power
Optical Power Output	1.6 mW / 2 dBm	
Optical Distance	≤1 km	Notes 1, 2

Note 1: P<sub>in</sub> = -20 dBm (Standard), P<sub>in</sub> = +17 dBm (Option HIL)

Note 2: 8 MHz window

Note 3: with back-to-back fiber connection (1 m)

Note 4: minimum 10 dB CNR margin for single audio carrier

**DEV 7286 & DEV 7387 Desktop CWDM Optribution Modules**

Technical Data	Value	Condition
<b>Common Optical Specifications</b>		
Fiber Type	Single Mode 9/125 $\mu$ m	
Optical Connector	LC/APC or LC/PC	Standard is LC/APC
<b>Tx Specifications (DEV 7286)</b>		
Laser Type	DFB	
Laser Class (according to IEC 60 825-1)	Class 1M (low Risk to Eyes, no Risk to Skin)	
Available CWDM Wavelengths	(9 different Wavelengths)	Note 1
Impedance, Connectors	75 Ohm , precision F (f) or 50 Ohm, BNC (f)	Standard is 75 Ohm, precision F (f)
Insertion Loss Monitor Port	= Input Level +12 $\pm$ 3 dB	
Power Consumption Module	12 V; 250 mA	
<b>Rx Specifications (DEV 7387)</b>		
Wavelength Range	1260...1620 nm	
Impedance, Connectors	75 Ohm, precision F (f) or 50 Ohm, BNC (f)	Standard is 75 Ohm, precision F (f)
Insertion Loss / Flatness Monitor Port	Output Level $\pm$ 3 dB	
Power Consumption Module	12 V; 300 mA	
<b>Tx &amp; Rx Optical Monitor</b>		
Optical Status Indication	Via LED at the Front Panel	
<b>Tx &amp; Rx External Power Supply</b>		
Primary Voltage	100...240 V AC	
Power Consumption Power Supply	typ. <20 VA	
<b>Tx &amp; Rx General Specifications</b>		
Size	5.43" (138 mm) Length, 1.65" (42 mm) Width, 0.9" (23 mm) Height	
Weight	~0.1 kg	
Operating Temperature	-20...+65 $^{\circ}$ C (-4...+150 $^{\circ}$ F) with Overtemperature Protection	
Environmental Conditions	ETSI EN 300 019 Part 1-3 Class 3.1E	Except Temperature

Note 1: Please refer to the Order Information section for the available wavelength options.

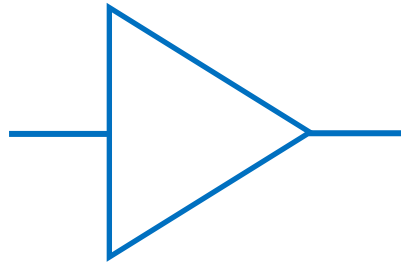

## DEV 6087 Desktop Amplifier Module

Technical Data	Value	Condition
<b>Rx Specifications</b>		
Frequency Range	450...960 MHz	
Impedance, Connectors	50 Ohm, BNC (f)	
Gain	33±2 dB	
Gain Stability vs. Temperature	<0,4 dB per 10 °C change	-20...+65 °C (-4...+150 °F)
Flatness	±2 dB	
Input Level	<-15 dB	
Nominal Output Level	>+17 dBm	
OP1dB	>+24 dBm	
IM3	>40 dBc	@ 2 tones, -21 dBm each
Return Loss	min. 12 dB, typ. 15 dB	
<b>External Power Supply</b>		
Primary Voltage	100...240 V AC	
Power Consumption	<3 VA	
<b>General Specifications</b>		
Size	5.43" (138 mm) Length, 1.65" (42 mm) Width, 0.9" (23 mm) Height	
Weight	~0.1 kg	
Operating Temperature	-20...+65 °C (-4...+150 °F)	
Environmental Conditions	ETSI EN 300 019 Part 1-3 Class 3.1E	Except Temperature

## Order Information

### Product and Options

A Desktop Optribution module is delivered in a handy storage case, holding the module and an external plug-in power supply with different interchangeable AC plugs.

DEV 7286 Desktop CWDM Optribution Transmitter; 450...960 MHz; LC/APC

#### Wavelength Options:

<u>Option</u>	<u>Wavelength</u>	<u>Option</u>	<u>Wavelength</u>
Lambda 0	1310 nm	Lambda 5	1550 nm
Lambda 1	1470 nm	Lambda 6	1570 nm
Lambda 2	1490 nm	Lambda 7	1590 nm
Lambda 3	1510 nm	Lambda 8	1610 nm
Lambda 4	1530 nm		

Option 01 50 Ohm, BNC (f) instead of 75 Ohm, F (f) Connectors

Option 10 Change LC/APC to LC/PC Connector

Option HIL High Input Level (+17 dBm)

DEV 7387 Desktop TV Optribution Receiver; 47...1006 MHz; LC/APC

Option 01 50 Ohm, BNC (f) instead of 75 Ohm, F (f) Connectors

Option 10 Change LC/APC to LC/PC Connector

The Desktop Amplifier module is delivered in a handy storage case, holding the module and an external plug-in power supply with different interchangeable AC plugs.

DEV 6087 Desktop Amplifier; 450...960 MHz

## Contact

DEV Systemtechnik GmbH  
Grüner Weg 4A  
61169 Friedberg  
GERMANY  
Phone: +49 6031 6975 100  
Fax: +49 6031 6975 114  
info@dev-systemtechnik.com  
www.dev-systemtechnik.com

Rev. 17-Jan-2024

### Disclaimer

The information contained herein is believed to be reliable. DEV Systemtechnik makes no warranties regarding the information contained herein. DEV Systemtechnik assumes no responsibility or liability whatsoever for any of the information and for the use of the information contained herein. The information contained herein is provided "AS IS" and with all faults, and the entire risk associated with such information is entirely with the user. All information contained herein is subject to change without notice. Customers should obtain and verify the latest relevant information before placing orders.